

THIS DRAWING IS UNPUBLISHED. RELEASED FOR PUBLICATION
 © COPYRIGHT BY TYCO ELECTRONICS CORPORATION. ALL INTERNATIONAL RIGHTS RESERVED.

LOC	DIST	REVISIONS			
P	LTR	DESCRIPTION	DATE	DWN	APVD
AJ	16	K	REV PER ECO 08-023708	10/17/2008	DW FB

1. USE INSTRUCTION SHEET 1799-2

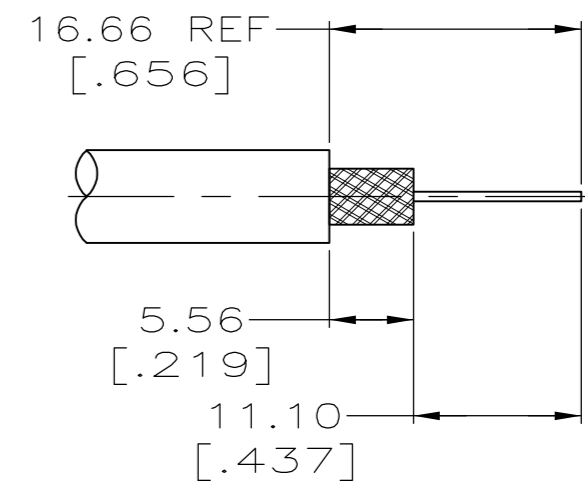
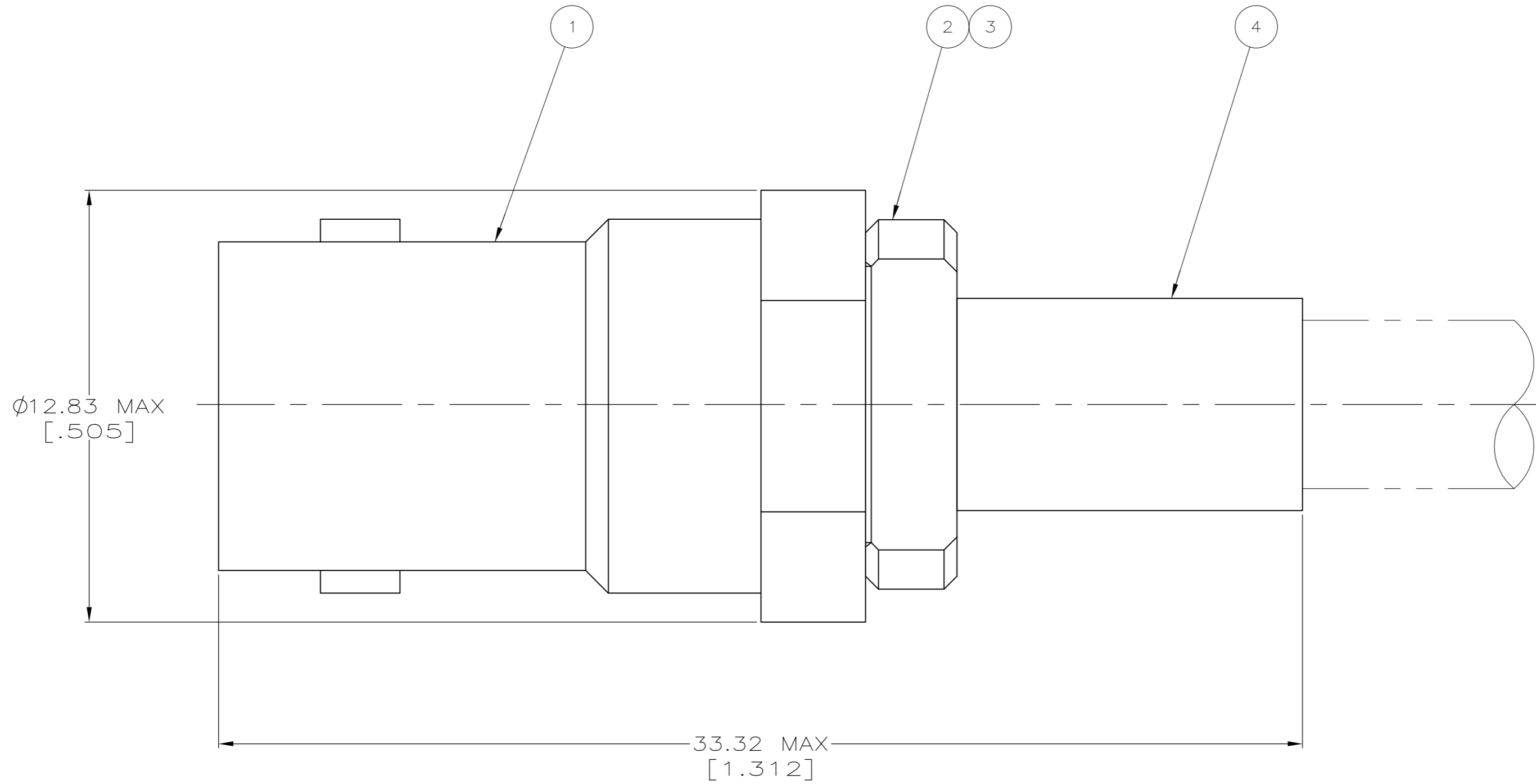

RECOMMENDED STRIP LENGTH
SCALE 2:1

OBSOLETE	RG-141 & 141A	69331-1	330478	50793-1	2-329106-1	329802	2-329452-3
	RG-142/U, 142A/U, AND 142B/U	69331-1	329099	50793-1	2-329106-1	329802	2-329452-2
SUPERSEDED BY 2-329545-1	RG-58/U, 58A/U, 58B/U, AND 58C/U	69140-1	328663	50793-1	2-329106-1	329802	2-329452-1
SUPERSEDED BY 2-329452-1	RG-58/U, 58A/U, 58B/U, AND 58C/U	69140-1	328663	50793-1	2-329106-1	329802	329452
	FOR USE WITH	CRIMP TOOL	④ FERRULE QTY=1	③ CRIMP END ASSEMBLY QTY=1	② GASKET QTY=1	① JACK ASSEMBLY QTY=1	PART NUMBER

Finish		Material		Part Number
THIS DRAWING IS A CONTROLLED DOCUMENT.		DWN 14FEB96 MICHAEL E. COWHER		Tyco Electronics Corporation Harrisburg, PA 17105-3608
DIMENSIONS: mm		CHK 15FEB96 FRANK P. MORANA		
TOLERANCES UNLESS OTHERWISE SPECIFIED:		APVD 15FEB96 FRANK P. MORANA		NAME JACK, BNC
0 PLC ± -	1 PLC ± -	PRODUCT SPEC		SIZE A2
2 PLC ± 0.41 [0.016]	3 PLC ± -	APPLICATION SPEC		CAGE CODE 00779
4 PLC ± -	ANGLES ± -	WEIGHT -		DRAWING NO C=329452
MATERIAL -	FINISH -	CUSTOMER DRAWING		RESTRICTED TO -
SCALE 8:1				SHEET 1 OF 1
REV K				

3294529452